

Analysis of Errors in Active Power and Energy Measurements Under Random Harmonic Distortion Conditions

Kiril Demerdziev, Vladimir Dimchev

Institute of Electrical Measurements and Materials, Faculty of Electrical Engineering and Information Technologies (FEET), Ss. Cyril and Methodius University in Skopje (UKIM), st "Rugjer Boskovik" No.18, Skopje, North Macedonia
kdemerdziev@feit.ukim.edu.mk, vladim@feit.ukim.edu.mk

As harmonic distortion of voltage and current is reality in the power system, the need for accurate measurement of electrical power and energy goes beyond the instruments' specifications and calibration procedures regarding pure sine wave signals. Several international standards and recommendations provide test signals for examination of electricity meters under non-sinusoidal conditions, however, not all of the test signal parameters' possible states are faithfully represented in those documents. Because the high order harmonics may possess random amplitudes and phase shifts in relation to components at fundamental frequency, it is important that the meter's performance is verified with random waveforms as well. The non-linear dependence between the measured power/energy and the phase shifts, both between fundamental and harmonic components, provides additional complexity of such an analysis. Simple test signals, which are in accordance with the standards' demands and propositions, are used for determination of the measurement error in case of different harmonic distortion parameter change. In order for a general error function for any measurement device to be determined, mathematical modelling, regarding the results from multiple tests, is performed. The mathematical model presents a strong dependence between a single component's phase shifts and a meter's error and it provides a systematization of all signal parameters' influence on the measurement accuracy.

Keywords: High order harmonics, phase shift, error function, electricity meter, reference standard.

1. INTRODUCTION

High order harmonics in voltage and current waveforms are an undesirable occurrence in the power system and most commonly are the result of non-linear loads, such as: arc furnaces and welding equipment, lighting installations with discharge lamps and LEDs, battery chargers, rectifiers [1]-[3], etc. Distorted signals cause problems in power networks and result in increased electrical and magnetic losses, high current flow through the neutral conductor and insulation ageing of the electrical equipment. The effects of high frequency components on the constructive parts of measurement equipment may further lead to inaccurate measurement of the system's parameters. This is especially important to be analyzed in details in case of electricity meters, intended for legal metrology purposes [4].

There are several international standards and recommendations which comply with the need for electricity meter examination under non-sinusoidal conditions. In the international standard EN 50470 [5]-[7], test signals regarding calibration of active energy meters, in case of harmonically distorted voltages and currents, are presented. These documents [5]-[7] are widely accepted in practice and are used as a base for many research papers [8]-[12]. An

example of test signals, used for examination of static electricity meters for active energy, are voltage and current waveforms comprising 5th order harmonics, beside components at fundamental frequency [7], [8], [10]. The share of the 5th order voltage harmonic equals 10 % of the fundamental's value, while for the 5th order current harmonic the share equals 40 % of the 50 Hz component's magnitude. Both voltage and current harmonics are in phase with fundamentals at positive zero crossing. Another example of an international document for active energy meter calibration, in which test signals comprising harmonics are proposed, is OIML R 46-1/-2 Recommendation [13]. In [13], 2 harmonically distorted signal sets are presented, called Quadriform waveform and Peaked waveform. Both test signals possess similar limitations for voltage and current distortion as stated in [7], and the single harmonic components are either in phase, or 180° displaced, in accordance with fundamental ones.

In some research papers [8]-[9], [14]-[16] test signals, with random harmonic share and phase shifts, are presented. These scientific works comply with the need for evaluation of the meter's error in accordance to: the degree of harmonic distortion [8], [12], the presence of harmonic components at certain frequency [16], the duration of the disturbances [10],

and their effect on the instrument's measuring principle [11]. None of the papers presented deal with the effects of a single harmonic distortion parameter on the power and energy meters' errors. The need for such an analysis is important because of several reasons:

- voltage and current distortion is not limited to a single harmonic component, as test procedure proposed in [7] suggests,
- high order harmonics may possess totally random phase shifts in relation to voltages and currents at fundamental frequency, which is not the case with test signals proposed in [13],
- amplitudes of high order harmonics, in single point of the network, can be significantly higher, or lower than the constraints introduced in [7] and [13].

In the following work, the effects of single distortion parameters such as: harmonic order, amplitude (or share in the signal) and phase shift on instruments for active power and energy will be examined. High accuracy electricity meter for active energy, based on Digital Signal Processing (DSP), will be used as Unit Under Test (UUT). The test procedure which is going to be performed will encompass simple distorted waveforms, as proposed in [7], but with accent on the parameter change effect on the meter's output. The measurement errors obtained, because of harmonic's order, magnitude and phase shift change, will be introduced into a mathematical model. Later, the model is going to be validated with complex test signals, comprising several high frequency components, with random amplitudes and phase shifts, and a high accuracy class measurement equipment.

2. THEORETICAL BACKGROUND

A voltage or current signal which, beside the component at 50 Hz, possesses high order harmonics up to n^{th} order, can be expressed in the time domain using Fourier series [1]-[2]:

$$x(t) = \sqrt{2} \sum_{h=1}^n X_h \sin(h\omega t + \alpha_h), \quad (1)$$

where X_h is the RMS of the harmonic component of order h , α_h is its phase shift and ω is the angular frequency. The number of high frequency components regarded in the waveform of the signal is usually limited at 50th harmonic [3]. The RMS of the distorted signal is calculated as:

$$X_{RMS} = \sqrt{\sum_{h=1}^n X_h^2}, \quad (2)$$

while for distortion quantification, the parameter Total Harmonic Distortion – *THD* is used [3], [17]:

$$THD = \frac{\sqrt{\sum_{h=2}^n X_h^2}}{X_1} \cdot 100. \quad (3)$$

Because for the purposes of this work electricity meters are regarded, the quantity of particular interest is active power or

active energy. Single phase active power, in case of distorted waveforms, is expressed as follows [17]:

$$P = \frac{1}{T} \int_0^T u(t)i(t)dt = \sum_{h=1}^n U_h I_h \cos \varphi_h, \quad (4)$$

where, $u(t)$ and $i(t)$ are the time varying voltage and current signals according to (1), U_h and I_h are the RMS values of the h^{th} order harmonic components, and φ_h is the phase shift between them. When distorted waveforms are regarded, it is often the case, that single harmonic components are expressed as percentage values, $x_h[\%]$, of fundamental voltage's or current's magnitude, X_1 . The phase shift of a high order harmonic is also presented in relation to the voltage or current at fundamental frequency [7], [13]. Taking the last statements into account, the RMS of the h^{th} order harmonic of voltage or current can be expressed as follows:

$$X_h = \frac{x_h[\%]}{100} X_1, \quad (5)$$

while the phase shift between the voltage and the current, having h times higher frequency than the system's nominal, is calculated as [18]:

$$\varphi_h = h\varphi_1 + \theta_{ih} - \theta_{uh}, \quad (6)$$

φ_1 being the phase shift between the voltage and the current at 50 Hz, while θ_{ih} and θ_{uh} are the phase shifts between the h^{th} order harmonics of current and voltage and the components at fundamental frequency. The multiplication of φ_1 by the order of harmonics h , stands for the fact that the phasors of the high frequency components rotate h times faster than the phasors of U_1 and I_1 .

When an instrument is intended for active power measurement, (4) is the starting point for further analysis. When the UUT is an electricity meter, an additional quantity, i.e. time, is supposed to be also taken into account. However, electricity meter's performance will be observed from the perspective of its measurement capabilities for active power recording. This assumption is adopted for 2 reasons. First, taking into account the fact that the time factor is not affected by harmonic distortion, the additional error because of single high frequency component will be reproduced as error of the h^{th} order power component measurement. The second reason is based on basic metrological knowledge, that voltage and current measurement errors exceed the errors in time measurement in orders of magnitude scale.

3. MEASUREMENT EQUIPMENT AND PROCEDURES

The experimental part of the work was performed in the Laboratory of Electrical Measurements (LEM), which is part of the Faculty of Electrical Engineering and Information Technology (FEEIT) at Ss. Cyril and Methodius University in Skopje (UKIM). It is an accredited laboratory for calibration of instruments and reference standards for a variety of electrical quantities, according to international standard ISO EN MKC 17025:2018 [19]. The metrological

traceability chain of this laboratory, in domain of electrical power and energy instruments calibration [20]-[21], consists of 2 reference standards, illustrated in Fig.1.:

- ZERA COM3003, digital three phase electrical power and energy comparator of accuracy class 0.01, used as primary reference standard for three phase, low frequency voltages and currents, active, reactive and apparent power, power factor and energy [22],
- CALMET C300, three phase voltage and current source of accuracy class 0.02, used as a laboratory working standard for calibration of low-level accuracy electricity meters and other AC measurement equipment [18].

The secondary standard, CALMET C300 [18], plays the central role in the experiments conducted in this work. It is software controlled and can be used for electricity meter error examination. A 3 phase 4 wire connection of an electricity meter to the reference standard [18] is illustrated in Fig.2. The pulses procession on UUT's pulse output is proportional to

the measured energy. These pulses are recorded via optical head (photo transducer) and are an input signal in the reference standard's pulse input via external circuit for signal conditioning and data acquisition. The results from the test procedure are automatically calculated and presented in relative (percentage) error form as follows:

$$\varepsilon = \frac{P_{UUT} - P_{C300}}{P_{C300}} 100, \quad (7)$$

where P_{UUT} is the measured power (energy) by the meter being tested and P_{C300} is the power (energy) generated by the reference standard [18]. The automated error test can be performed with pure sine wave signals, and with distorted waveforms as well. The distortion parameters, i.e. single harmonics' share and phase shift, are manually set by the user. In case of examination procedure with non-sinusoidal waveforms, the value of generated active power is calculated as declared in (4)-(6).



Fig.1. Primary and secondary reference standards of LEM in the domain of electrical power and energy.

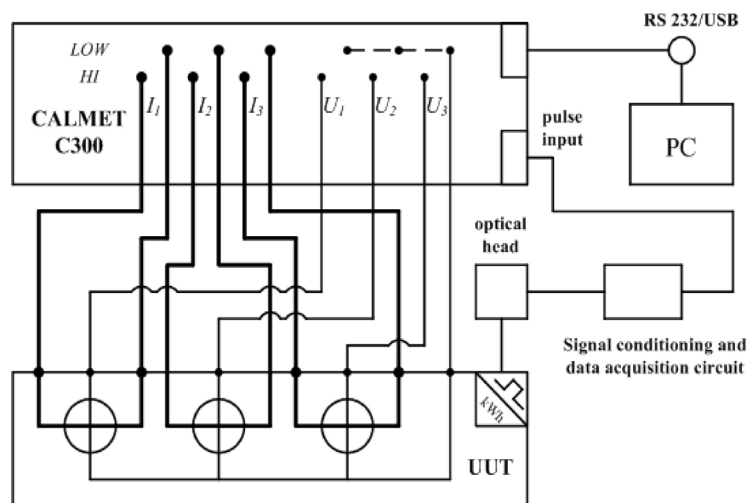

Fig.2. Scheme for 3 phase electricity meter testing with CALMET C300.

The practical part of the analysis presented in this work is divided into 2 parts. The first part consists of a high accuracy active energy meter examination with distorted waveforms. The role of the UUT is played by an electricity meter for active energy, intended for instrument transformer connection, Landys+Gyr ZMD405CT44.2407, 3x58 V/ 100 V, 5 A, 50 Hz, accuracy class 0.5S [23]. Its measuring principle is based on DSP, i.e. on averaging the instantaneous power:

$$P_{UUT} = \frac{1}{N} \left[\sum_{k=1}^N u_{1k} i_{1k} + \sum_{k=1}^N u_{2k} i_{2k} + \sum_{k=1}^N u_{3k} i_{3k} \right], \quad (8)$$

where u_{1k} , u_{2k} , and u_{3k} are the instantaneous voltage samples for all 3 phases, i_{1k} , i_{2k} , and i_{3k} are the instantaneous current samples for all 3 phases and N is the number of samples obtained during the averaging period. The connection of this UUT to the reference standard [18] is illustrated in Fig.2.

A total of 5 test procedures is conducted on the concrete UUT. In every measurement procedure only one high order harmonic component is present in the waveforms, beside the fundamental voltages and currents. Additionally, in every procedure only one parameter (harmonic order, amplitude, or phase shift) of the test signals is variable, while all the others are held constant. Procedures consist of several sub-procedures, which correspond to a different value of the harmonic parameter being changed. Sub-procedures are determined by 9 measurement points, which correspond to a different phase shift between fundamental voltages and currents, φ_1 , ranging from -60° to 60° , with a step of 15° . The RMS of the voltage and current signals are held constant during the measurements and are equal to the UUT's nominal values, 58 V and 5 A. The values of harmonic parameters for every measurement procedure are illustrated in Table 1. The symbol ν in every column of Table 1. denotes that the parameter is variable in the concrete procedure.

As stated earlier, the results from testing of the UUT [23] with CALMET C300 [18] are presented as percentage errors using (7). In order for the UUT's measurement output to be determined, it is more convenient for errors to be expressed in absolute form:

Table 1. Harmonic parameters values in every measurement procedure.

Procedure	Value of the specific harmonic parameter				
	h	u_h [%]	i_h [%]	θ_{uh} [°]	θ_{ih} [°]
1	5	10	40	0	ν
2	5	10	40	ν	60
3	5	10	ν	0	60
4	5	ν	40	0	60
5	ν	10	40	0	60

$$\Delta P = P_{UUT} - P_{C300}, \quad (9)$$

and that can be accomplished by using the results obtained from the automated error tests and (7):

$$\Delta P = P_{C300} \frac{\varepsilon}{100}. \quad (10)$$

From the error results obtained during the first part of the practical analysis, the measurement output for electricity meter, based on DSP, can be modelled mathematically. In order for the assumptions and conclusions obtained from the model to be validated for other meters of this type and for different values of the harmonic components' parameters, other electricity meters [24]-[25] and the primary reference standard of LEM, ZERA COM3003 [22] will be used as UUT. In the second part of the practical analysis, the reference standard [22] will be tested with more complex, non-sinusoidal signals, which are going to encompass several high order harmonic components, with random magnitudes and phase shifts. The connection of ZERA COM3003 [22] to the harmonic source, CALMET C300 [18] is similar to the connection of any low accuracy class electricity meter, illustrated in Fig.2. The primary reference standard [22] is used for 2 reasons:

- to provide justification of the mathematical model regarding active power/energy measurement error of an instrument based on DSP, for any complex signals comprising harmonics with random order, magnitude and phase shift, and
- to provide justification of the secondary standard's output [18] in domain of single harmonic component generation; in such a scenario it is used as a power quality analyzer and single voltage and current harmonic components are monitored independently.

4. CASE STUDY

The first measurement procedure is carried out with waveforms similar to those proposed in [7]. The test voltage comprises a 50 Hz component and a 5th order harmonic, which possess a magnitude equal to 10 % of the fundamental's value and is in phase with U_1 at positive zero crossing. A 5th order harmonic component is also present in the current signal and its magnitude equals 40 % of I_1 . The phase shift of the current harmonic, θ_{i5} , is variable during the measurements and that defines single sub-procedures. The measurement results are presented in form of errors in absolute form, as stated in (9) and (10), and are illustrated in Fig.3. as different curves for every measurement sub-procedure.

As can be seen from Fig.3., error intensity changes in every measurement sub-procedure, and these variations can be mathematically represented as a sine wave function of φ_1 . The period of these functions equals 72° , i.e. $360^\circ/5$, while their numerical representation can be written as:

$$\Delta P = K_1 \sin(5\varphi_1), \quad (11)$$

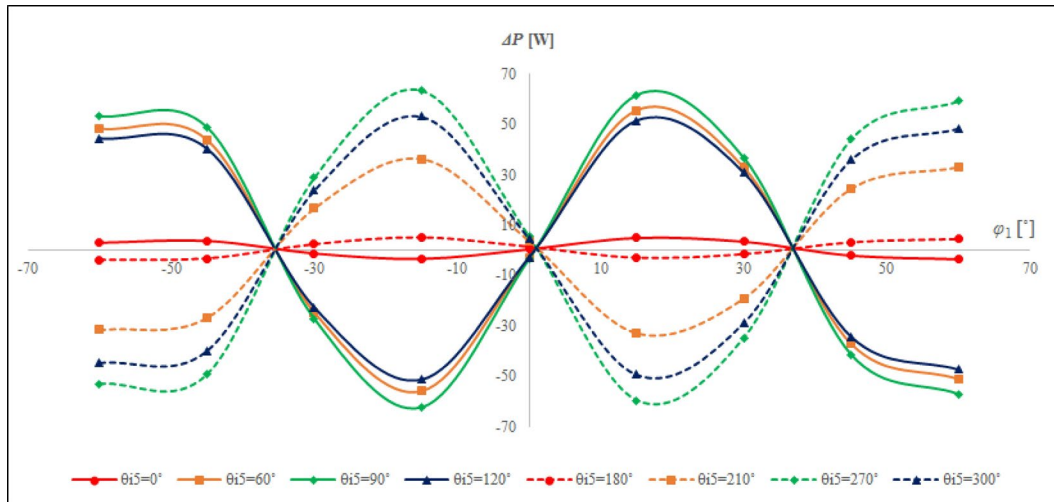

Fig.3. Errors in active power measurement $\Delta P = f(\varphi_1)$, for different θ_{i5} , $u_5[\%] = 10\%$, $i_5[\%] = 40\%$, $\theta_{u5} = 0^\circ$.

where the amplitude K_1 is strongly dependent on θ_{i5} , taking into account that all other parameters are constant in every measurement sub-procedure. The amplitude of the error function is small when θ_{i5} equals 0° , in that case the electricity meter is within its accuracy class, for most test points. Errors increase as θ_{i5} increases, when $\varphi_1 \neq 0^\circ$ they go beyond the accuracy class of the UUT and are maximal when $\theta_{i5} = 90^\circ$. From this point onwards, K_1 commences to decrease and is minimal once again for $\theta_{i5} = 180^\circ$, but with opposite polarity. For the “capacitive” range of θ_{i5} , an increase in errors when this parameter changes in the interval between 180° and 270° is recorded, while in the range between 270° and 360° , errors decrease to the minimal value. In terms of relative errors, maximal values are recorded in the measurement points which correspond to a $\pm 60^\circ$ phase shift φ_1 . In the sub-procedures in which θ_{i5} equals 0° or 180° , the ε_{max} lies between $\pm 0.8\%$ and $\pm 1.2\%$. On the other hand, in the sub-procedures which correspond to a $\pm 90^\circ$ value for θ_{i5} , errors as high as $\pm 15\%$ are recorded for the same values of φ_1 .

The second measurement procedure is similar to the first one, except that the phase shift θ_{i5} is fixed at 60° , while each

sub-procedure is defined by the value of θ_{u5} . The errors ΔP are illustrated in Fig.4., presented as a function of φ_1 .

Fig.4. certifies that errors, when 5th order harmonic components are present, can be mathematically evaluated using (11). They are minimal when $\theta_{u5} = 60^\circ$, which indicates that the error amplitude, K_1 , is not dependent solely on θ_{i5} , but on the difference $\theta_{i5} - \theta_{u5}$. In terms of relative errors, for the concrete sub-procedure, ε_{max} lies between $\pm 0.9\%$ and $\pm 1.1\%$. If that conclusion is adopted, then K_1 is minimal when $\theta_{i5} - \theta_{u5} = 0^\circ$ and increases up to the point where $\theta_{i5} - \theta_{u5} = 90^\circ$ ($\theta_{u5} = 330^\circ = -30^\circ$), then decreases and is once again minimal, with opposite polarity, for $\theta_{u5} = 240^\circ = -120^\circ$. Further on, the error function amplitude increases up to the point where $\theta_{i5} - \theta_{u5} = 270^\circ$, that is, in the particular case for $\theta_{u5} = 150^\circ$, and then decreases up to the point where $\theta_{u5} = 60^\circ$. Not all of these measurement sub-procedures were conducted, however, from those performed, the appropriate conclusions can be derived. In order for the dependence $K_1 = f(\theta_{i5} - \theta_{u5})$ to be obtained, the first two measurement data sets are reorganized into an additional data set, in which every curve corresponds to a different value of φ_1 , see Fig.5.

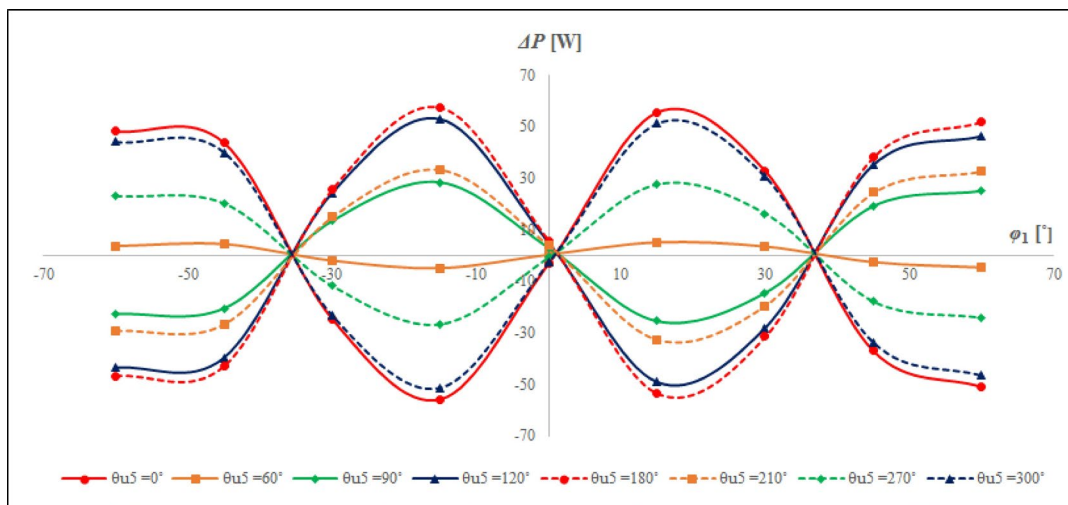

Fig.4. Errors in active power measurement $\Delta P = f(\varphi_1)$, for different θ_{u5} , $u_5[\%] = 10\%$, $i_5[\%] = 40\%$, $\theta_{i5} = 60^\circ$.

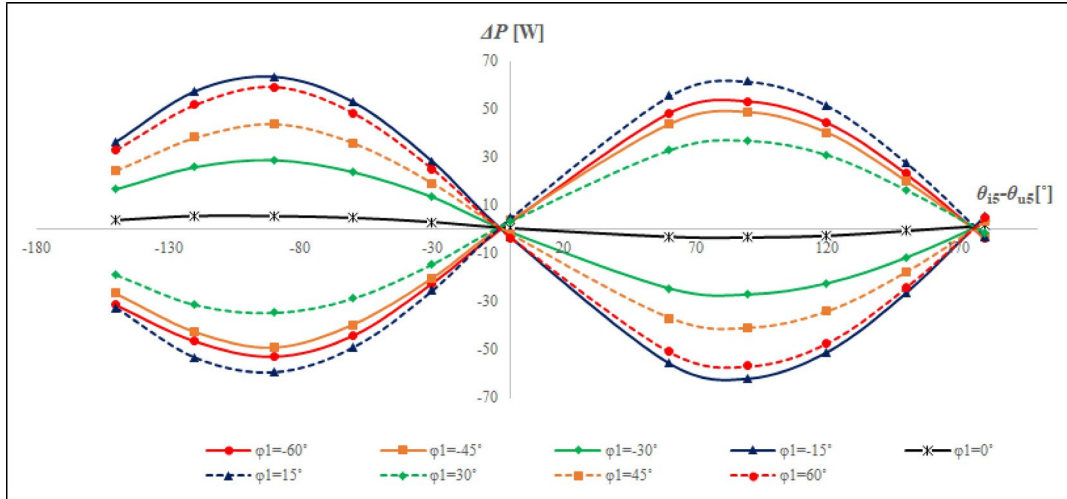

Fig.5. Errors in active power measurement $\Delta P = f(\theta_{is}-\theta_{us})$, for different $\varphi_1, u_5[\%] = 10 \%, i_5[\%] = 40 \%$.

In Fig.5., the dependency between the measured error and the phase shift difference $\theta_{is}-\theta_{us}$ is illustrated, for different values of φ_1 . As can be seen, the error function follows a sine wave pattern with a period of 360° . The amplitude of single curves is dependent on φ_1 , and is maximal for $\varphi_1 = -15^\circ$ and $\varphi_1 = 15^\circ$, taking into account that the peaks of the error functions illustrated in Fig.3. and Fig.4. are the measurement points which correspond approximately to the same φ_1 values. From the results presented in Fig.5., (11) is reorganized as:

$$\Delta P = K_2 \sin(5\varphi_1) \sin(\theta_{is} - \theta_{us}), \quad (12)$$

where K_2 is an error component related to other signals' parameters. In order for K_2 to be mathematically evaluated, third and fourth measurement procedures are performed.

In the third measurement procedure, once again only 5th order harmonics are regarded. Phase shifts θ_{us} and θ_{is} are held constant at 0° and 60° , respectively. The amplitude of

voltage's 5th order harmonic is held constant at 10 % of U_1 , while the amplitude of 5th order current harmonic is variable in the interval between 20 % and 40 % of I_1 , with a step of 5 %. In Fig.6.a) errors are illustrated as a function of φ_1 and as can be seen they follow the same sine wave pattern, for every $i_5[\%]$. The difference in the single error function amplitude is proportional to the share of the 5th order current harmonic, taking the fact that all other parameters in the measurement procedure are held constant. In terms of the UUT's accuracy class, the relative errors are maximal when $\varphi_1 = \pm 60^\circ$ and their value lies between $\pm 6 \%$ when $i_5[\%] = 20 \%$ and $\pm 12.5 \%$ when $i_5[\%] = 40 \%$. The reorganized data is presented in Fig.6.b), where each subset corresponds to a different phase shift φ_1 , and errors are illustrated as a function of $i_5[\%]$. It can be concluded that deviations in active power (energy) measurements possess a linear relationship with the amplitude of the current harmonic, and when $i_5[\%] = 0 \%$, i.e. when the current signal possesses a pure sine form, $\Delta P \approx 0$ W.

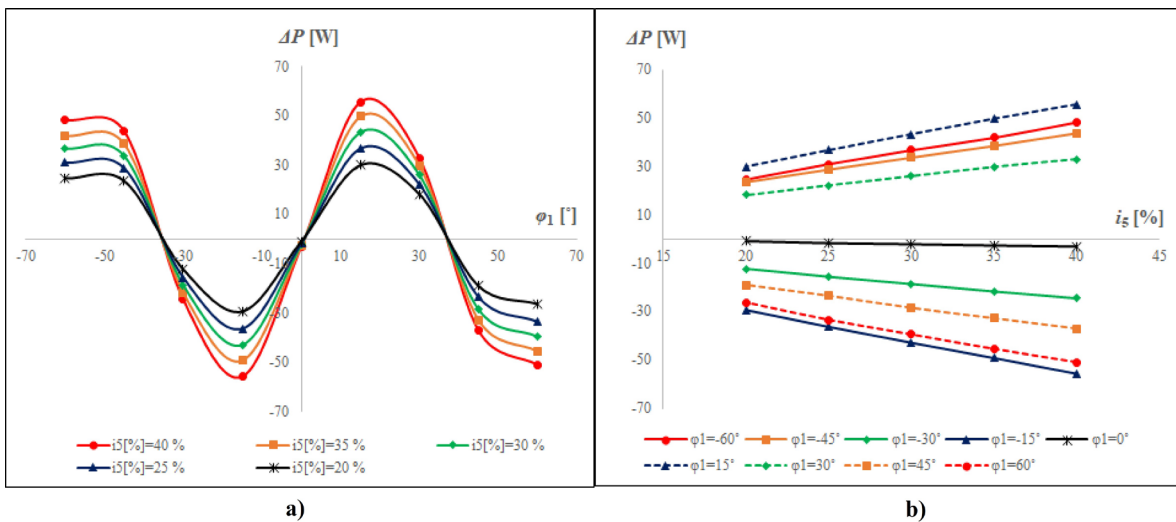

Fig.6. Errors in active power measurement: a) $\Delta P = f(\varphi_1)$, for different values of $i_5[\%]$, b) $\Delta P = f\{i_5[\%]\}$, for different values of φ_1 ; $u_5[\%] = 10 \%, \theta_{us} = 0^\circ, \theta_{is} = 60^\circ$.

Similar conclusions can be derived from the fourth measurement procedure, the results from it are illustrated in Fig.7. The 5th order voltage harmonic share possesses different value for every measurement sub-procedure, while all other signal parameters are held constant. From Fig.7.a) it can be concluded that the error function possesses different amplitude for different values of the 5th order voltage harmonic, the highest being for $u_5[\%] = 10\%$, while the lowest corresponds to $u_5[\%] = 2.5\%$. The maximal relative errors, as indicated for the UUT's performance in accordance with its accuracy class, vary between $\pm 3.2\%$ for $u_5[\%] = 2.5\%$ and $\pm 12.5\%$ when $u_5[\%] = 10\%$. Fig.7.b) represents the linear relationship between ΔP and $u_5[\%]$ for different ϕ_1 values. The error is approximately 0 W, when there is no harmonic distortion of the voltage signal.

Taking the conclusions of the last two measurement procedures into account, (12) is rewritten as follows:

$$\Delta P = K_3 3U_5 I_5 \sin(5\phi_1) \sin(\theta_{i_5} - \theta_{u_5}), \quad (13)$$

where U_5 and I_5 are the RMS values of the 5th order voltage and current harmonics, as they are proportional to $u_5[\%]$ and $i_5[\%]$ according to (5). The multiplication factor 3 stands for the fact that the electricity meter is a 3 phase instrument, and K_3 is a coefficient, which is not dependent on any harmonic parameter of the signal. From the measurement results obtained, K_3 equals approximately 2 for every test point. Taking the previous discussion into account, the error function, when only the 5th order voltage and current harmonics are regarded in the test waveforms, equals:

$$\Delta P = \Delta P_5 = 3[2U_5 I_5 \sin(5\phi_1) \sin(\theta_{i_5} - \theta_{u_5})], \quad (14)$$

In the last test procedure, for every sub-procedure, only one order of harmonic signals is taken into account: 5th, 7th, 9th, and 11th. The amplitudes of the harmonic components are constant, $u_h[\%] = 10\%$ and $i_h[\%] = 40\%$, in every sub-procedure, and the phase shifts are fixed at $\theta_{uh} = 0^\circ$ and $\theta_{ih} = 60^\circ$. Measurement results $\Delta P = f(\phi_1)$ are illustrated in Fig.8.

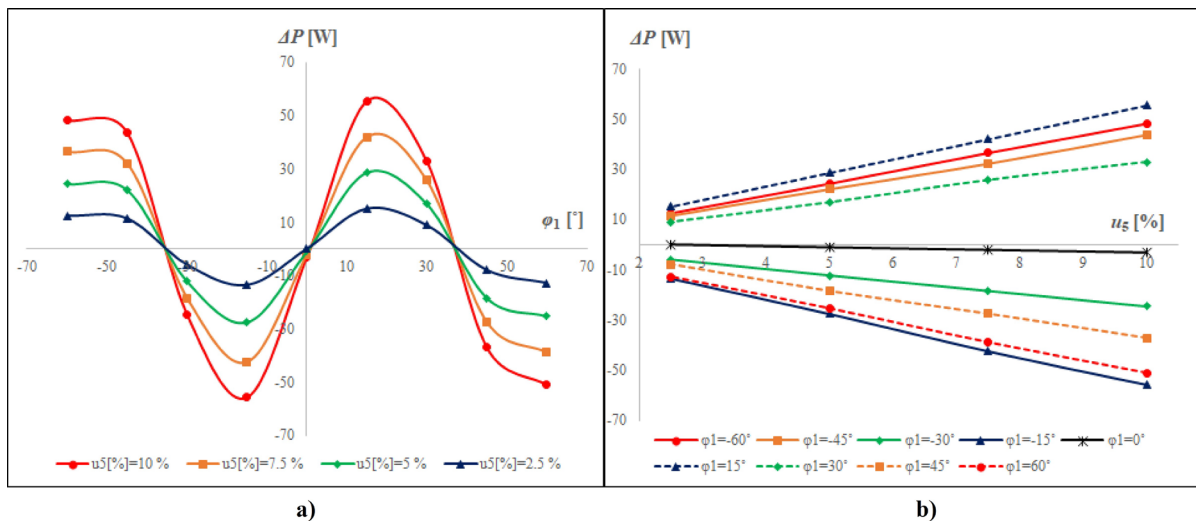

Fig.7. Errors in active power measurement: a) $\Delta P = f(\phi_1)$, for different values of $u_5[\%]$, b) $\Delta P = f\{u_5[\%]\}$, for different values of ϕ_1 ; $i_5[\%] = 40\%$, $\theta_{u_5} = 0^\circ$, $\theta_{i_5} = 60^\circ$.

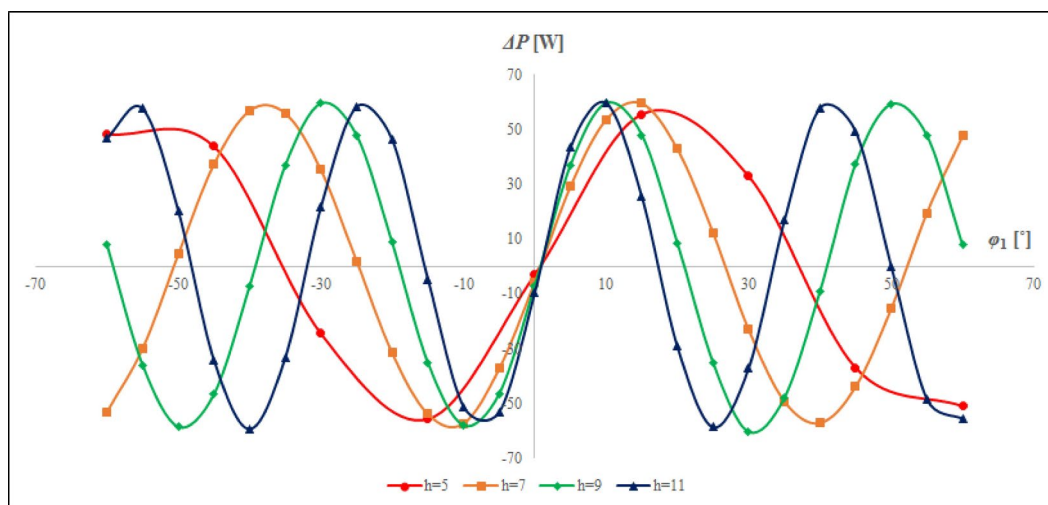

Fig.8. Errors in active power measurement $\Delta P = f(\phi_1)$, for different harmonic order, h , $u_h[\%] = 10\%$, $i_h[\%] = 40\%$, $\theta_{uh} = 0^\circ$, $\theta_{ih} = 60^\circ$.

As can be seen from Fig.8., for all test signals, the error function follows a sine wave pattern of φ_1 . Its period changes with variation of the harmonics' order, while the amplitude is constant, taking into account the fact that it depends on the harmonics' amplitudes and phase shifts which are fixed for every sub-procedure. From Fig.8. it can be concluded that the period change is inversely related to the harmonic order:

$$T_h = \frac{360^\circ}{h}. \quad (15)$$

If these statements are adopted, (14) can be rewritten in a general manner:

$$\Delta P_h = 3[2U_h I_h \sin(h\varphi_1) \sin(\theta_{ih} - \theta_{uh})] \quad (16)$$

where all the parameters with index h are correlated to a specific harmonic order h .

An additional measurement data set is presented, as a conclusion of the first part of practical analysis. The following measurement results are recorded during an examination procedure performed on 4 instruments for active power/energy, in order for a general acceptance of the error function, presented in (16), to be adopted. The 4 active power/energy instruments used in the concrete procedure as a UUT are:

- Landys+Gyr ZMD405CT44.2407 [23], i.e. the electricity meter used in the previous analysis,
- LEM's primary reference standard, ZERA COM3003 [22], used as 3 phase active power indicator,
- Landys+Gyr ZMD310CT44.0000 [24], an active energy meter for direct connection of accuracy class 1, 3x220 V/ 380 V, 20 A, 50 Hz,
- ISKRA MT173 [25], an active energy meter for direct connection of accuracy class 2, 3x220 V/ 380 V, 10 A, 50 Hz.

The test is performed with voltage and current waveforms which comprise the 5th order harmonics beside components at

fundamental frequency. The share of the voltage and current harmonics equal 10 % and 40 % of the fundamentals, respectively, and their phase shifts are fixed at $\theta_{u5} = 0^\circ$ and $\theta_{i5} = 60^\circ$. The three electricity meters are tested with signals that match their nominal voltage and current, while the primary reference standard ZERA COM3003 is tested with 220 V and 5 A RMS values. As was the case in the previously conducted 5 measurement procedures, 9 measurement points are used for illustration of the error function, which correspond to phase shifts φ_1 between -60° and 60° , with a step of 15° . The results from the test are illustrated in Fig.9.

From Fig.9. a sine wave envelope of the error function $\Delta P = f(\varphi_1)$ is recorded for all 4 measurement devices. The difference between the error functions' intensity is due to the fact that, every measuring device is tested with voltages and currents with different amplitudes. According to (16) the errors are proportional to the RMS of the harmonic components, which are, according to (5), proportional to the fundamental voltages and currents. An error function with the greatest amplitude is recorded when the examination is performed on Landys+Gyr ZMD310CT44.0000, because this device is tested with the highest voltage and current signals, $U = 220$ V and $I = 20$ A, respectively. The lowest absolute errors are recorded in the measurements encompassing Landys+Gyr ZMD405CT44.2407, because the test signals' RMS equal only $U = 58$ V and $I = 5$ A. If the results are regarded in a relative (percentage) form, then similar values for the errors are recorded in all 4 tests. The maximal relative errors for all 4 electricity meters are present in the measurement points which correspond to $\pm 60^\circ$ phase shift between U_1 and I_1 . The errors' values in the concrete test points vary between $\pm 10.5\%$ and $\pm 12.5\%$. The period of all error functions follows (15), i.e. it equals $360^\circ/5 = 72^\circ$, even though the zero crossing is displaced, especially in the case of the function corresponding to the ISKRA [25] meter. These phenomena can be explained with a higher base error of this meter, in case of sine wave signals, taking into account the fact that this device is of a lower accuracy class.

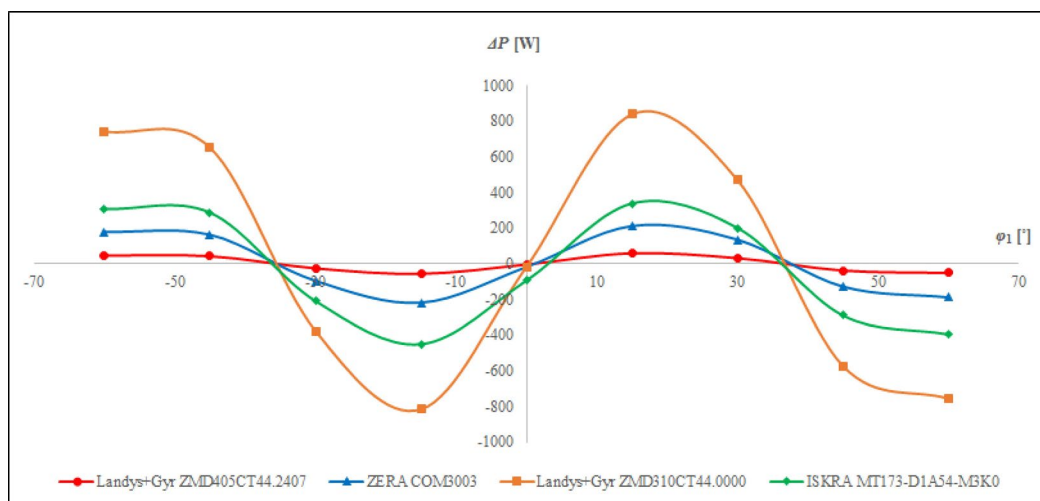

Fig.9. Errors in active power measurement $\Delta P = f(\varphi_1)$, for different measurement devices, $u_5[\%] = 10\%$, $i_5[\%] = 40\%$, $\theta_{u5} = 0^\circ$, $\theta_{i5} = 60^\circ$.

5. MATHEMATICAL MODEL AND VALIDATION

Equation (16) represents a mathematical model for error calculation in active power and energy measurements, when only one harmonic component exists in the voltage and current signals. It can be expanded in order for deviations of more complex signals to be determined. Taking into account the fact that in (16) no correlation exists between the high order harmonics and the fundamental components at 50 Hz, a more general expression can be presented:

$$\Delta P_{\Sigma} = 3 \sum_{h=2}^n 2U_h I_h \sin(h\varphi_1) \sin(\theta_{ih} - \theta_{uh}). \quad (17)$$

The power generated by the reference standard [18] is calculated via (4) and multiplied by 3, for a three phase system. If (9) and (10) are regarded, the power measured by the UUT equals:

$$P_{UUT} = P_{C300} + \Delta P_{\Sigma} = 3 \sum_{h=1}^n U_h I_h \cos \varphi_h + 3 \sum_{h=2}^n 2U_h I_h \sin(h\varphi_1) \sin(\theta_{ih} - \theta_{uh}). \quad (18)$$

The second part of (18) can be rewritten using a well-known trigonometric identity and (6) as:

$$P_{UUT} = 3 \sum_{h=1}^n U_h I_h \cos \varphi_h + 3 \sum_{h=2}^n U_h I_h [\cos(h\varphi_1 - \theta_{ih} + \theta_{uh}) - \cos \varphi_h] = P_1 + 3 \sum_{h=2}^n U_h I_h \cos(h\varphi_1 - \theta_{ih} + \theta_{uh}), \quad (19)$$

where P_1 is the fundamental power. From (17) and (19) several conclusions are derived. First, the meter will measure the power/energy generated by the reference standard, with minimal additional error, in any case when the fundamental voltages and currents are mutually in phase, no matter the harmonics' phase shifts and amplitudes, as long as they are limited to the standard's [7] values. The errors will be low even if $\varphi_1 \neq 0^\circ$, but only when single harmonic components are in phase with voltages and currents at fundamental

frequency or if they are 180° displaced, at the positive zero crossing. Both statements are backed up by the general error function presented in (17). The second conclusion which can be derived from the measurements conducted and the mathematical model presented is the fact that the energy meter regards the high harmonics as components which rotate in opposite direction compared to the fundamental ones. This statement is obtained by comparison of (4), (6) and (19) in the domain of high order harmonics' phase shift calculation.

An experimental validation of the proposed mathematical model is conducted, for confirmation that the measurement principle presented using (19) is valid for instruments based on DSP and for random harmonic distortion of voltage and current waveforms. For the validation procedure, LEM's primary reference standard, ZERA COM3003 [22], is used as UUT. Beside the active power measuring principle, with the laboratory's primary reference standards, single harmonic components' amplitudes and phase shifts, generated by CALMET C300 [18], are validated as well. For that purpose, ZERA COM3003 is used as a power quality analyzer. The validation procedure is conducted with 3 test signals, the share and phase shifts of each high order component in these signals is presented in Table 2.

In the 3 test signals, high frequency components up to the 11th order are regarded, with only odd harmonics taken into account. Only 2 constraints are applied, the voltage harmonics do not result in THD_U higher than 10 %, while the current harmonics do not result in THD_I higher than 40 %, as stated in [7] and [13]. A total of 9 measurements for every signal set is performed, each one corresponding to a different phase shift, φ_1 , between -60° and 60° , with a step of 15° . The characteristics of the 3 signal sets are different, in order for a general acceptance of the mathematical model to be provided. Signal set 1 is considered as a case with high harmonic distortion present in a low voltage network, where the instrumentation is intended for direct connection, or connection via current transformer, $U = 230 \text{ V}$, $I = 5 \text{ A}$. Signal set 2 represents a case with a lower harmonic distortion, present in a medium or high voltage network, i.e. the instrument is intended for connection via instrument transformers, $U = 58 \text{ V}$, $I = 1 \text{ A}$. Signal set 3 is once again an example of a low voltage network disturbance, with absence of triplen harmonics, $U = 230 \text{ V}$, $I = 20 \text{ A}$.

Table 2. Harmonic components in 3 random signal sets for validation of the mathematical model.

h	Signal set 1				Signal set 2				Signal set 3			
	u_h [%]	θ_{uh} [°]	i_h [%]	θ_{ih} [°]	u_h [%]	θ_{uh} [°]	i_h [%]	θ_{ih} [°]	u_h [%]	θ_{uh} [°]	i_h [%]	θ_{ih} [°]
3	8.2	65	34.9	119	5.22	63	23.15	17	0	0	0	0
5	4.4	247	15.1	194	1.98	224	11.53	312	6.93	95	28.7	328
7	1.15	174	8.5	48	0.83	117	6.89	94	2.81	266	14.33	65
9	0.78	12	2.45	7	0.21	336	1.84	222	0	0	0	0
11	0.12	325	0.87	204	0	0	0	0	0.96	148	3.19	185
THD [%]	9.41		39.05		5.65		26.83		7.54		32.24	

The test results are illustrated in Fig.10., Fig.11., and Fig.12. For each signal set, 3 curves are illustrated. The first curve, the solid line with dots, labeled as $\Delta P_{\Sigma,Z-C}$, resembles the measurement errors. Measurement errors are the differences between the actual value three phase active power measured by the primary reference standard [22] and the value applied by the harmonic source, i.e. secondary standard [18]. This difference is calculated via (9), where P_{UUT} , is the active power measured with ZERA COM3003 [22]. The dashed line with square points, labeled as $\Delta P_{\Sigma,cal}$, represents the error function calculated with the mathematical model. Single points on this curve are obtained if the generated signals' parameters, that are entered in CALMET C300 [18], are inserted into (17). The third curve, presented as dashed line with triangular points, named $\Delta P_{\Sigma,Z-Z}$, resembles the deviation between the actual three phase active power measured by the primary reference standard [22], and the calculated power using the same instrument as a power quality analyzer. From the mathematical point of view, the points on this curve are obtained by using (9), P_{UUT} is the measured 3 phase active power by ZERA, while instead of P_{C300} , the calculated active power, using (4)-(6), from the measured single harmonics is used.

As can be seen from Fig.10., Fig.11., and Fig.12. for all 3 test signals, measurement errors made by the reference standard [22] comply with measurement errors calculated with (17). This conclusion is derived by comparison between $\Delta P_{\Sigma,Z-C}$ and $\Delta P_{\Sigma,cal}$ curves for all 3 waveforms. In some measurement points, a small mismatch exists and it is the result of an additional error existence because of increased losses due to high order harmonics. These errors are not regarded in the mathematical model, (17) and (19), but can be covered by the expanded measurement uncertainty of both standards, in case of non-sinusoidal voltages and currents. The third curve in the figures, $\Delta P_{\Sigma,Z-Z}$, gives additional justification of the model, because it provides assurance of the secondary standard's output. In the end it can be concluded that for random harmonic distortion, the envelope of the error function follows the sine wave pattern of the dominant harmonic order components, that being the 3rd order harmonics for signal sets 1 and 2, Fig.10. and Fig.11., and the 5th order harmonics for signal set 3, Fig.12. The measuring points are chosen with a 15° margin for ϕ_1 , if this step is lower, more realistic error curve will be provided for both real measurements and calculation results.

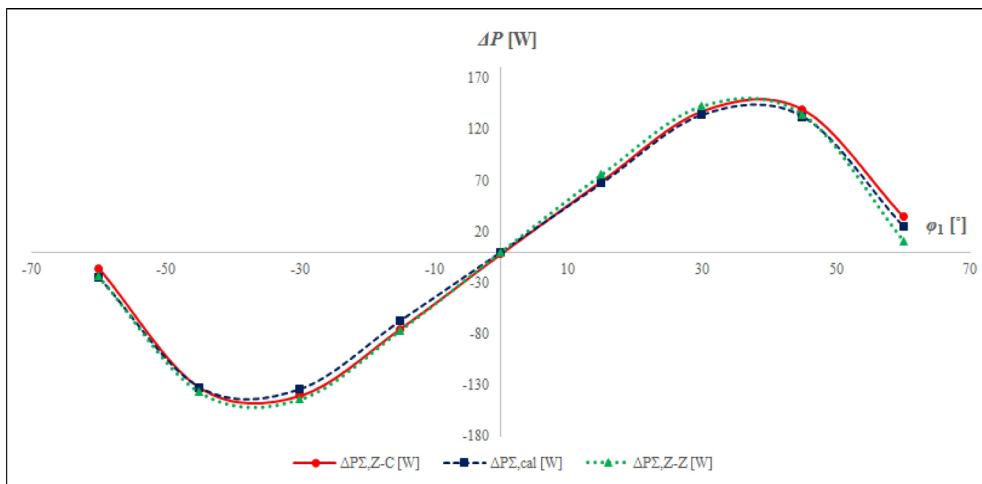

Fig.10. Errors in active power measurements with ZERA COM3003 for Signal set 1.

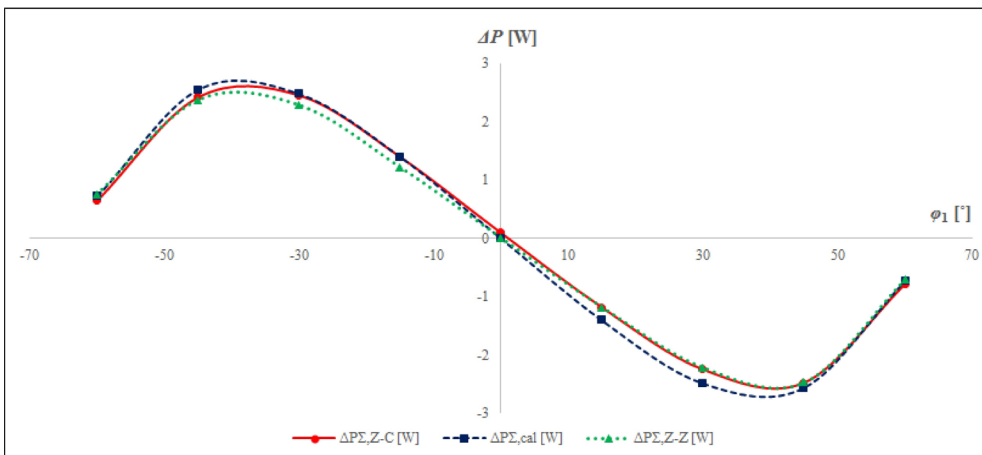

Fig.11. Errors in active power measurements with ZERA COM3003 for Signal set 2.

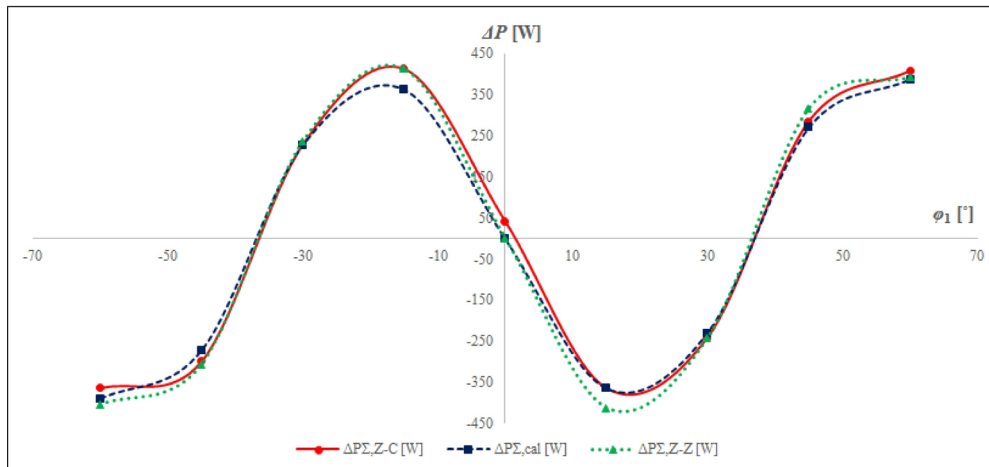

Fig.12. Errors in active power measurements with ZERA COM3003 for Signal set 3.

6. CONCLUSION

In the work, an experimental approach for mathematical modelling of active power and energy instruments' measurement error, when voltages and currents are non-sinusoidal, is presented. The model is developed, starting from real measurements, conducted on a high accuracy class electricity meter, when only one harmonic order component is present in both voltage and current signals. The measurements are performed with different distorted waveforms, regarding alteration of different harmonic parameters, i.e. amplitudes and phase shifts. The whole experiment is conducted in an accredited calibration laboratory, with reference standards traceable to BIPM.

From the measurement results and later from the mathematical model itself, it can be concluded that errors in active power and energy measurements are low when the phase shifts between fundamental and harmonic components equal to 0° or 180° . If that is the case, errors are comparable to errors when the UUT is exposed to pure sine wave signals, with an additional component due to increased losses in the constructive elements of the instrument. When only one harmonic order components are present, which are not mutually in phase and there is also a phase shift between fundamental voltages and currents, a significant error in measurement exists. This error can be as high as $\pm 15\%$ and even more, depending on the harmonic components' magnitudes. The error change can be represented with a sine wave function, whose period is inversely proportional to the harmonics' order. Its magnitude depends also on the phase shifts between harmonics, in relation to fundamental components being maximal for phase shift of $\pm 90^\circ$. The reason for this error existence can be found if an additional analysis on a digital electricity meter is performed. This analysis is supposed to provide an explanation on the measurement process' stage in which an alteration of the harmonic voltages' and currents' phase shifts occurs. The reason for an alteration of phase shifts is about to be revealed if input and output signals are recorded in every 4 signal conditioning and processing stages by a digital electricity

meter for active energy: analog signal conditioning, sampling, A/D conversion, and digital processing.

In the end, a validation of the model is provided by testing the laboratory's primary reference standard, ZERA COM3003, with random harmonically distorted signals. It can be concluded that the proposed mathematical model for error determination suits random harmonic distortion, as well. In some measurement points, deviation exists between the measured and calculated error. This deviation is primary because the model itself does reflect only the measurement principle of a device intended for active power/energy measurements, and does not encompass the increased losses due to higher frequency components. The other thing to be highlighted is the fact that the primary reference standard does not possess documented specification for high order harmonics phase shift measurements. It is challenging for future research, this type of specifications to be provided by experimental means for additional improvement of the mathematical model itself and for establishment of a metrological traceability chain in the domain of non-sinusoidal voltages and currents within the laboratory.

REFERENCES

- [1] Zobia, A.F. (ed.). (2011). *Power Quality: Monitoring, Analysis and Enhancement*. IntechOpen, ISBN 978-953-307-330-9.
- [2] Grady, M. (2006). *Understanding power system harmonics*. Austin, TX: University of Texas.
- [3] Santoso, S., McGranaghan, M.F., Dugan, R.C., Beaty, H.W. (2012). *Electrical Power Systems Quality, 3rd Ed.* McGraw-Hill Education, ISBN 978-0071761550.
- [4] European Parliament and of the Council. (2014). *EU Directive on Measuring Instruments (MID)*. 2014/32/EU.
- [5] European Committee for Electrotechnical Standardization (CENELEC). (2018). *Electricity metering equipment (a.c.) - Part 1: General requirements, tests and test conditions - Metering equipment (class indexes A, B and C)*. EN 50470-1:2006+A1:2018.

- [6] European Committee for Electrotechnical Standardization (CENELEC). (2018). *Electricity metering equipment (a.c.) - Part 2: Particular requirements - Electromechanical meters for active energy (class indexes A and B)*. EN 50470-2:2006+A1:2018.
- [7] European Committee for Electrotechnical Standardization (CENELEC). (2018). *Electricity metering equipment (a.c.) - Part 3: Particular requirements - Static meters for active energy (class indexes A, B and C)*. EN 50470-3:2006+A1:2018.
- [8] Olencki, A., Mróz, P. (2014). Testing of energy meters under three-phase determined and random nonsinusoidal conditions. *Metrology and Measurement Systems*, 21 (2), 217-232.
- [9] Masri, S., Khairunaz, M.D., Mamat, M.N. (2019). Study of electronic energy meter performance under harmonics current condition. In *10th International Conference on Robotics, Vision, Signal Processing and Power Applications*. Springer, 449-456. ISBN 978-981-13-6446-4.
- [10] Bartolomei, L., Cavaliere, D., Mingotti, A., Peretto, L., Tinarelli, R. (2020). Testing of electrical energy meters subject to realistic distorted voltages and currents. *Energies*, 13 (8), 2023.
- [11] Morva, G., Volokhin, V., Diahovchenko, I., Čonka, Z. (2017). Analysis of the impact of nonlinear distortion in voltage and current curves on the errors of electric energy metering devices. In *2017 IEEE First Ukraine Conference on Electrical and Computer Engineering (UKRCON)*. IEEE, 528-533.
- [12] Syafrudin, M., Mamat, M.N., Yahya, M.Y. (2017). An experimental study of the effect of current THD to kWh meter's energy measurement. *International Journal of Innovative Research in Electrical, Electronics, Instrumentation and Control Engineering*, 5 (2).
- [13] International Organization of Legal Metrology (OIML). (2012). *Active electrical energy meters. Part 1: Metrological and technical requirements and Part 2: Metrological controls and performance tests*. OIML R 46-2 & 1:2012.
- [14] Raza, S.S., Ahmad, M., Perveiz, M.S. (2014). Performance of energy meters under harmonic generating environment. *Science International (Lahore)*, 26 (5), 2063-2069.
- [15] Ferrero, A., Faifer, M., Salicone, S. (2009). On testing the electronic revenue energy meters. *IEEE Transactions on Instrumentation and Measurement*, 58 (9), 3042-3049.
- [16] Bartolomei, L., Cavaliere, D., Mingotti, A., Peretto, L., Tinarelli, R. (2019). Testing of electrical energy meters in off-nominal frequency conditions. In *2019 IEEE 10th International Workshop on Applied Measurements for Power Systems (AMPS)*. IEEE, 1-6.
- [17] Rangelov, Y. (2014). Overview on harmonics in the electrical power system. In *Electrical Power Engineering 2014: International Scientific Symposium*. Varna, Bulgaria: Technical University of Varna. ISBN 978-954-20-0497-4.
- [18] Calmet, Ltd. (2013). *300 three phase power calibrator and power engineering apparatus testing*. User's manual and extended specifications.
- [19] International Organization for Standardization (ISO). (2017). *General requirements for the competence of testing and calibration laboratories*. ISO/IEC 17025.
- [20] Demerdziev, K., Cundeve-Blajer, M., Dimchev, V., Srbinovska, M., Kokolanski, Z. (2018). Improvement of the FEIT Laboratory of Electrical Measurements Best CMC through Internationally Traceable Calibrations and Inter-Laboratory Comparisons. In *XIV International Conference ETAI*.
- [21] Demerdziev, K., Cundeve-Blajer, M., Dimchev, V., Srbinovska, M., Kokolanski, Z. (2019). Defining an uncertainty budget in electrical power and energy reference standards calibration. In *IEEE EUROCON 2019: 18th International Conference on Smart Technologies*. IEEE, 1-6.
- [22] ZERA GmbH. (2012). *COM3003 Three phase Comparator*. Operation manual.
- [23] Landys+Gyr. (2017). *ZMD400AT/CT E650 Series 4*. User manual.
- [24] Landys+Gyr. (2012). *ZMD300AT/CT E650 Series 3*. User manual.
- [25] Iskraemeco. (2010). *MT173 Three-phase static electricity multi tariff meter with maximum demand indicator and load-profile*. Technical description.

Received August 24, 2021
Accepted October 10, 2021